

Maiman

Superb Technology & Optimum Quality

Stone Series fiber green laser

Instruction manual

VN: FSL20240524



Tianjin Maiman Laser Technology Co., Ltd.

Preface

This manual is applicable to engineers who have basic knowledge of hardware and have a certain understanding of laser equipment and device. Please read through this manual carefully before using the Maiman laser products and keep it properly. If you have any questions, please contact Tianjin Maiman Laser Technology Co., Ltd.

For more product and information, please visit our website

www.maimanlaser.com



Content

1. Maiman Laser Safety Instructions	01
1.1 Declaration of Safe Use	01
1.2 Safety and Warning Signs	01
1.3 Guidelines for Safety Operation of the Laser	02
2. Product Installation Instructions	03
2.1 Laser Installation and Service Conditions	03
2.2 Supplied Accessories	04
2.3 Description of Laser Interface	05
2.4 Installation Instructions	07
2.4.1 Installation Method of Laser	07
2.5 Dimensional Drawing	08
3. Laser Operation Instructions	09
3.1 Startup Process	09
3.2 Shutdown Process	09
4. Troubleshooting and Maintenance	10
4.1 What should I do if the laser does not emit laser	10
4.2 The laser intensity becomes weak after working for a period of time	10
5. After sale service	11
5.1 Warranty	11
5.2 Returns	11

1. Maiman Laser Safety Instructions

1.1 Declaration of Safe Use

The manual must be read through carefully before using the Maiman laser, and operators must operate in strict accordance with the guidelines of the manual, so as to avoid the damage to the human body and property caused by improper operation. If the operator does not use the product in accordance with the guidelines of the manual, Tianjin Maiman Laser Technology Co., Ltd. will not bear any legal responsibility for all personal and property damages arising therefrom.

1.2 Safety and Warning Signs/Labels

	<p>Laser radiation warning sign Viewing visible or invisible laser light emanating from the laser will cause serious injury and potential blindness, as is reflected, scattered, and diffuse light.</p>
	<p>Safety Warning sign The specific procedures need to be followed, otherwise your device or parts may be damaged or will bring danger. You need to follow specific procedures, otherwise your equipment or components may be damaged or dangerous.</p>
	<p>The production label</p>
	<p>Anti disassembly label I . No warranty if the label is damaged.</p>
	<p>Anti disassembly label II .No warranty if the label is damaged.</p>
	<p>Maiman's logo</p>
	<p>QR code</p>



1.3 Guidelines for Safety Operation of the Laser

- The laser products of our company belongs to class IV laser device ($>500\text{mw}$) according to its output power level, The laser radiation will cause serious harm to human body, as well as fire and other hazards. Only qualified personnel who have been trained and are well aware of the danger of laser are allowed to operate this product. Non operators should evacuate outside the danger area of laser radiation.
- Do not open the casing of the laser body under any circumstances.
- Establish a safe operation area around the laser and take necessary measures to prevent the leakage of the laser. Post Class IV laser warning signs and safety warning signs at obvious positions in the safe operation area to prevent untrained personnel from entering.
- Store the laser in a place with certain power protection conditions, and all parts of the laser should have good grounding protection.
- Wear professional laser protective glasses, gloves, protective clothing, etc. during operation. Do not look at the laser beam directly without protective measures, do not touch the laser beam directly to avoid damage to eyes, skin, clothing, etc.
- Do not wear jewelry or any reflective objects, and do not irradiate the light beam on the reflective surface, so as to avoid personal injury caused by the reflected light.
- Take measures to block the reflected beam, or use a working platform with CLASS IV protection grade when processing metal parts which may reflect beam strongly.
- Keep the laser beam above or below the human eyes during operation, do not keep it on the same level as the human eyes.
- If volatile substances are used in the laser operation area, cleaned them out of the operation area immediately after the operation.
- After operation, the operator should check with the fluorescent sheet to confirm that the laser has been turned off before leaving.
- The maintenance and repair of the device should be carried out by professionally trained personnel. Be sure to refer to the relevant contents in the manual.

2. Product Installation Instructions

2.1 Laser Installation and Service Conditions

- Do not power on the laser during installation and disassembly, otherwise the laser will be burned; at the same time, pay attention to anti-static to avoid electrostatic breakdown of the internal laser diode;
- The working temperature of the laser is -5-40 °C, and too high or too low temperature will weaken the laser power;
- The laser power supply is a special switching power supply. Use the laser's own switching power supply. Do not replace it without permission. Connect the laser power supply cable correctly, otherwise the laser will be burned directly;
- Laser damage caused by human factors is not within the scope of warranty;
- No warranty if the anti disassembly label is damaged.

Remarks: beam expanders and window mirrors are not covered by warranty;

Category	Item	Specification
Electrical requirements	Switching power supply input voltage	AC100-240V, 50-60Hz
	Switching power supply output voltage/current	DC12V, 29A
	Laser input voltage/current	DC12V, 29A
	Running power	350W
Environmental requirements	Storage temperature	-10-40°C
	Storage humidity	<90%(No condensation)
	Operating temperature	-5 -40°C
	Operating humidity	<80%(No condensation)
	Dust	< 0.20mg/m ³
	Oil mist	Non
	Electromagnetic environment	GB Calss II
Shock	Isolate vibration sources	



2.2 Supplied Accessories

No.	Item	Picture	Qty	Unit	Description
1	Stone series fiber green laser		1	set	5W
2	15-pin plug		1	set	DB15 pin
3	9-pin housing		1	set	DB9 pin shell
4	Fixed feet screws		6	set	M3/M4
5	Fixed corners		2	set	-----
6	Beam combiner (green light only)		1	piece	532 beam combiner

Remark: The photos are for reference only, and the real object shall prevail.

2.3 Description of Laser Interface



- 25pin Ext control
(Fiber Optic Interface Signal Consistency)
- Power cable
- Optical fiber
- Fan cable

• Power connector

Provides DC constant voltage power supply for the laser. The laser is powered by the attached power supply cable and AC-DC switching power supply. Pay attention not to short circuit or connect incorrectly during wiring, otherwise the laser will be burned directly;

• Ext control (The laser supports both fiber and CO2 control.)

Fiber optic control mode, when using fiber optic control mode, please connect the fiber laser control interface of the board with the DB25 at the back of the laser driver, and select the FIBER mode in the control software, the DB25 pin is specifically defined as follows:

No.	Signal name	Illustrate
1-8	P0-P7	Laser power. TTL output.
9	PLATCH	Power latch signal. TTL output.
10,14	GND	Reference ground for the control card.
11,12	V2: Gnd	Reference ground for the control card.
	V3: SGIN2,SGIN3	Status input for the laser.
13,15,24	V2: Gnd	Reference ground for the control card.
	V3: NULL	This foot is suspended and unlinked.
16,21	SGIN4, SGIN1	Status input for the laser.
17	Vcc	5V power output from the control card.
18	MO	Main oscillator switching signal. TTL output.
19	AP	Power amplifier switching signal. TTL output.
20	PRR	Repeat pulse frequency signal. TTL output.
22	Out2	The red light indication signal of the laser. TTL output.
23	EMSTOP	Emergency stop switch signal. TTL output.
25		This foot dangles and is not linked.

• 15 pin Ext control

CO2 control mode, when using the CO2 control mode, please use the laser to drive the front panel of the DB15 pin serial port, and the board's PWM signal connected to the DB15 of the 5-pin, the board's GND and the DB15 pin 4-pin connection and in the control software to select the CO2 control mode can be, the DB15 pin specific definition is as follows: DB15 pin specific definition is as follows:

No.	Illustrate
1	NC
2	NC
3	NC
4	GND
5	PWM+
6	NC
7	NC
8	NC
9	NC
10	NC
11	NC
12	NC
13	NC
14	NC
15	NC

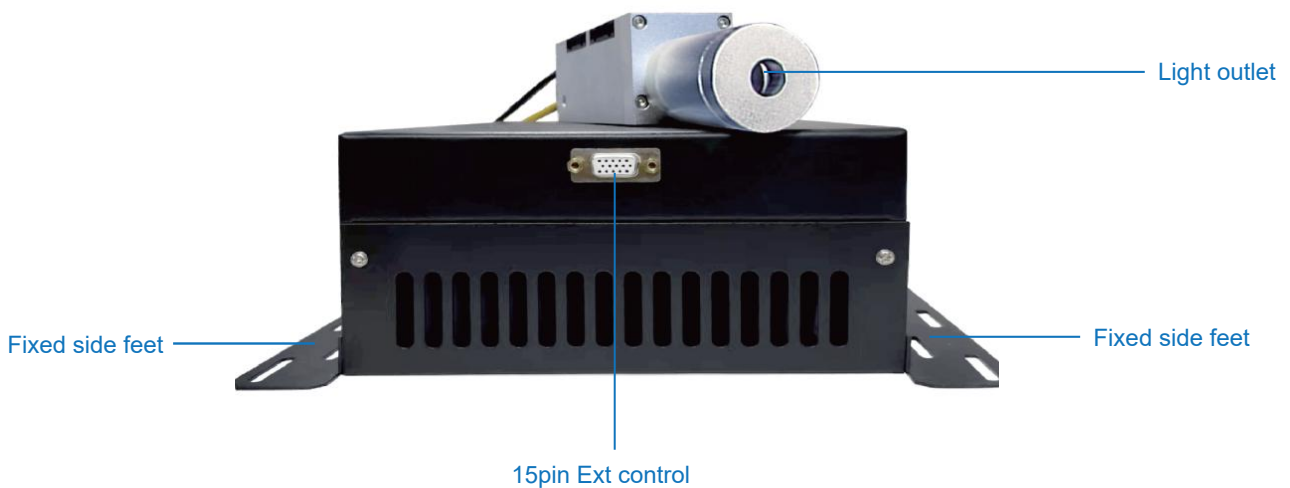

• Light outlet

The laser output port, with beam expanding lens, needs to be used in a clean environment.

• Fixed side feet

Fixed laser



2.4 Installation Instructions

2.4.1 Installation Method of Laser

Installation Notes

- This laser is extremely easy to install. First, connect the drive source to the 12V switching power supply. The red wire of the power cord is connected to the positive pole of the 12V switching power supply, the blue wire is connected to the negative pole of the 12V switching power supply, and the yellow-green wire is connected to the negative pole of the 12V switching power supply. The ground phase of the switching power supply is connected;

- Use our prepared temperature detection and control lines to connect the temperature detection and control interface of the laser driver to the 9-pin serial port of the laser output device;

- Connect the external control interface (15-pin serial port) of the drive source to the board.

The power, frequency and pulse width of the laser are only controlled by the marking software, so we provide an "external control interface" for data communication with the marking board, to achieve laser parameter adjustment.

Installation process

- Install the fixing feet to the bottom of the laser with the feet facing outward;
- Install the laser to the equipment side.

Remark: the mounting surface should be flat to ensure that the laser fixed feet fully fit the surface.



Fixed corners, Screws, The laser ▲

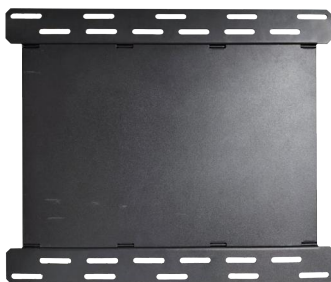

Bottom view of the laser after the fixed feet are installed ▲

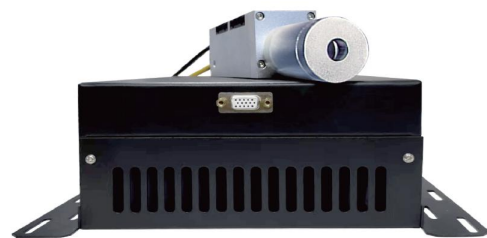

Install the fixed feet on to the laser ▲

2.5 Dimensional Drawing

Size reference

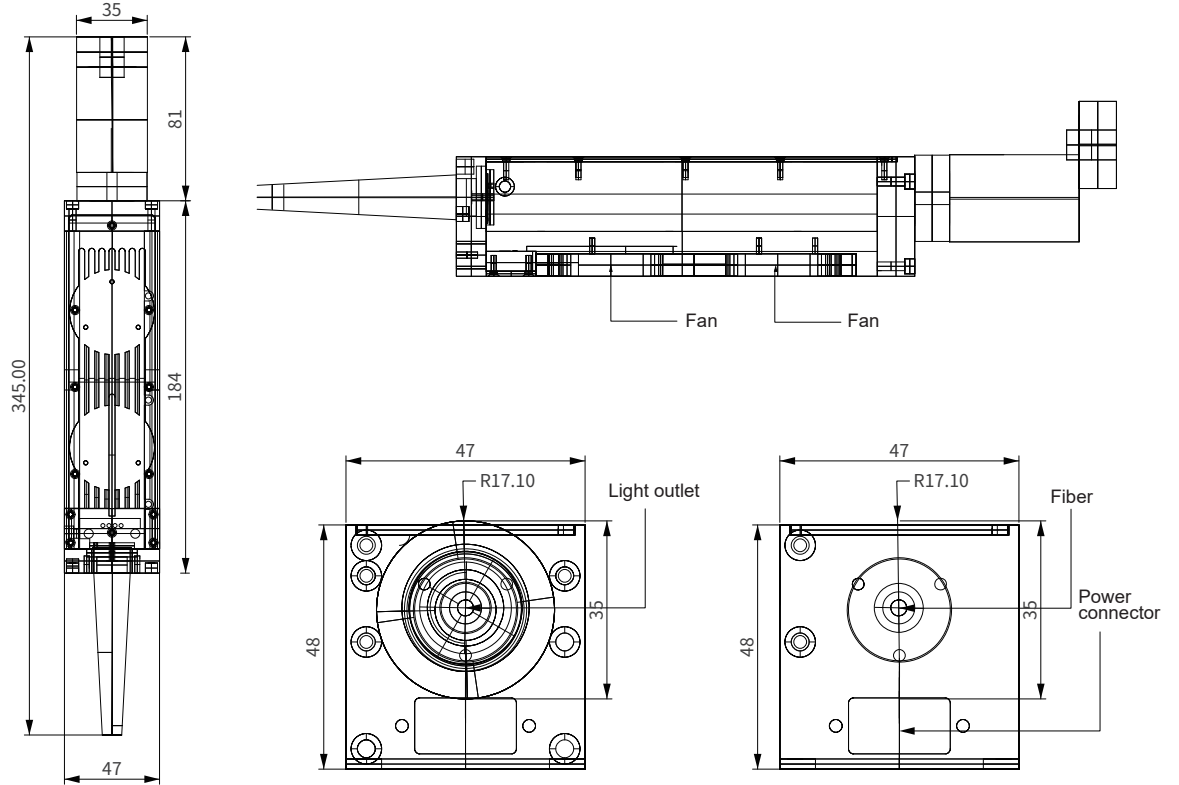

Driver

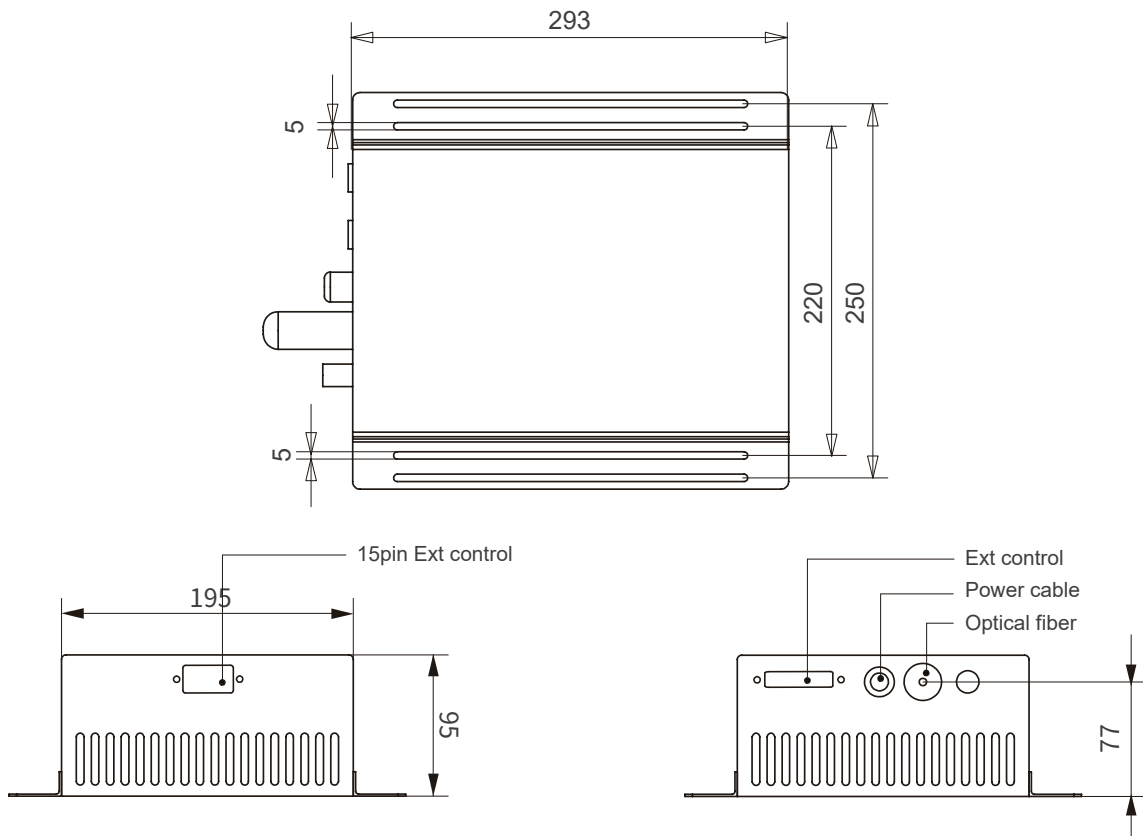

3. Laser Operation Instructions

3.1 Startup Process

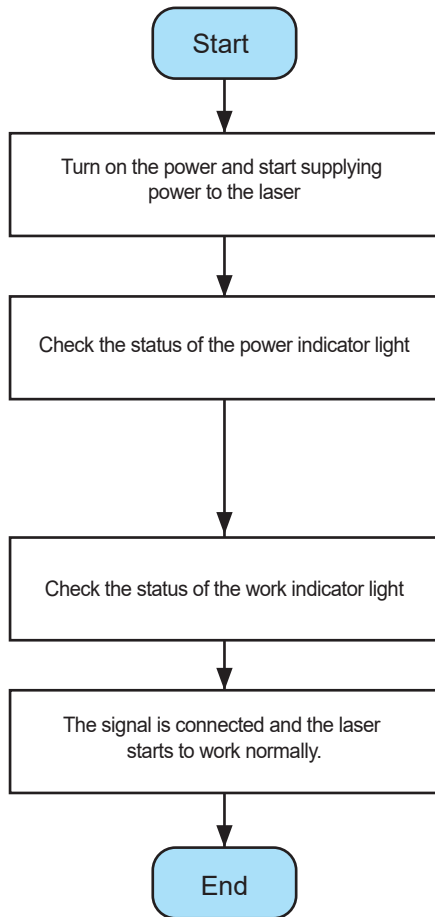

3.2 Shutdown Process

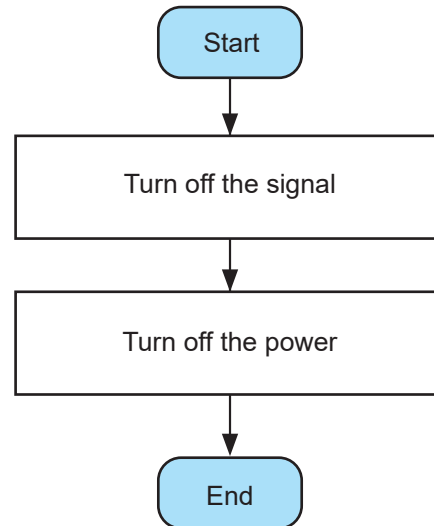

⚠ Notice:

- The external environment must be checked before starting up, and the laser equipment can be operated only after confirming that the power and protection systems are all normal.
- Before starting the machine, make sure that all interfaces are installed correctly and not loose. After starting the machine, do not plug or unplug the connection cable between the power supply and the laser, otherwise it will directly cause the laser to burn. If you find that the cable is loose or not connected, please turn off the phone first, and then tighten or connect it again.



4. Troubleshooting and Maintenance

4.1 What should I do if the laser does not emit laser?

- Whether the power is turned on, and whether the laser enters normal working status after the power is turned on.
- Check whether the control signal is correct.
- Confirm whether the signal cable plug is secure and whether there is poor contact.
- Check whether the voltage and power of the switching power supply are normal and whether the power supply line is correct.

4.2 The laser intensity becomes weak after working for a period of time?

- Whether the ambient temperature is too high or too low.
- Whether the field mirror and galvanometer are contaminated.

5. After sale service

5.1 Warranty

All laser source products from Tianjin Maiman Laser Technology Co., Ltd. come with an 18-month warranty period, which certifies that your laser is found to be free of any defects in material or workmanship. This warranty applies regardless of your laser application. It does not cover any issues that may arise due to operator negligence, environmental factors, accident, alterations, or improper maintenance. Tianjin Maiman Laser Technology Co., Ltd maintains the sole authority to make any claims or statements regarding warranty on its products. Maiman Laser reserves the right to make changes or improvements to product design without notice, and without expectation of equivalent changes in products previously manufactured or shipped.

5.2 Returns

If a failure should occur, please contact maimanlaser@maimanlaser.com or +86 17526524352. If a laser or accessories needs to be returned, a Return Merchandise Authorization(RMA) will be issued. Any laser returned without an RMA will be at your sole expense.

Typically, for failure within the 18 months, the client shall be responsible for shipping costs to Tianjin Maiman Laser Technology Co., Ltd. or its distributors. Maiman Laser or its distributors will pay all shipping costs to return the item(s) to the client.

When requesting an RMA please have the following information ready:

Date of purchase:

Date of receiving the laser:

Laser Model:

Date the issue was first discovered:

Brief description of the issue:

Find out the RMA as completely as possible. For any returns, please ship the item(s) to:

Tianjin Maiman Laser Technology Co., Ltd.

Attn: Overseas Department, Lynn Zhang

201, D6-A, East Huigu Industrial Park, Xiqing District, Tianjin, China

Include the laser and all accessories when returning the laser. This allows Maiman Laser to determine the source of the issue.

Tianjin Maiman Laser Technology Co., Ltd.

Address: 201, D6-A, East Huigu Industrial Park, Xiqing District, Tianjin

Tel: +86-22-8789 4207 8789 4217

Mobile: +86-22 175 2652 4352

Fax: +86-228789 4217

Web: www.maimanlaser.com

E-mail: maimanlaser@maimanlaser.com



[View website](#)



[View catalog](#)



WhatsApp

Tianjin Maimanlaser Technology Co., Ltd. reserves the copy right of this catlog and reserves all the rights to change the information and specifications contained in this catlog without prior notice.

Version updated on May 24th, 2024.